

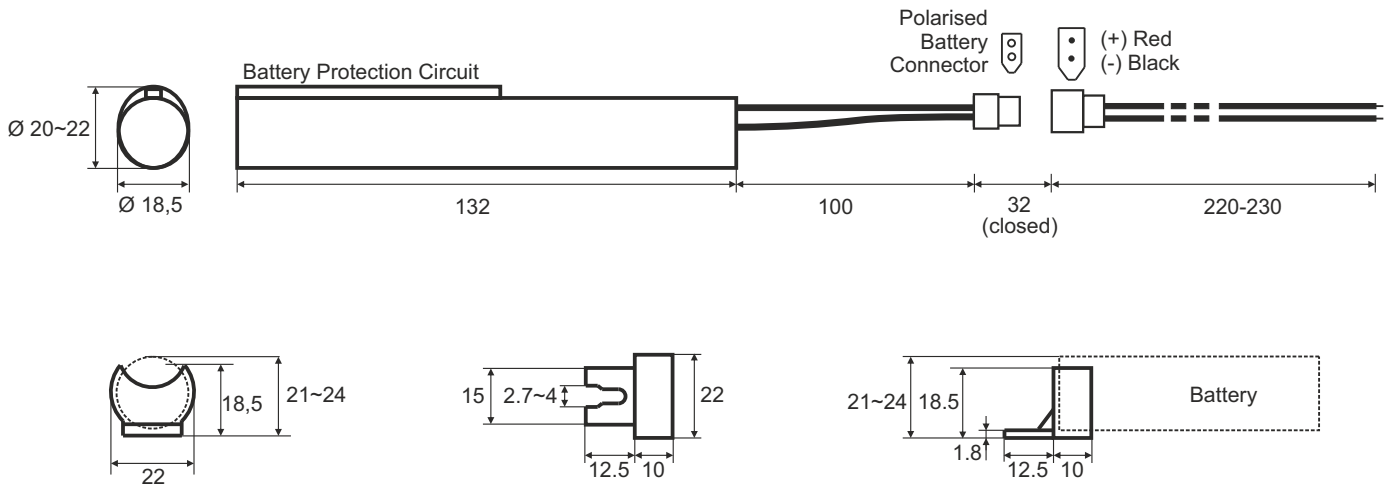

Battery Type : 6.4V-1.6Ah Li-FePO4

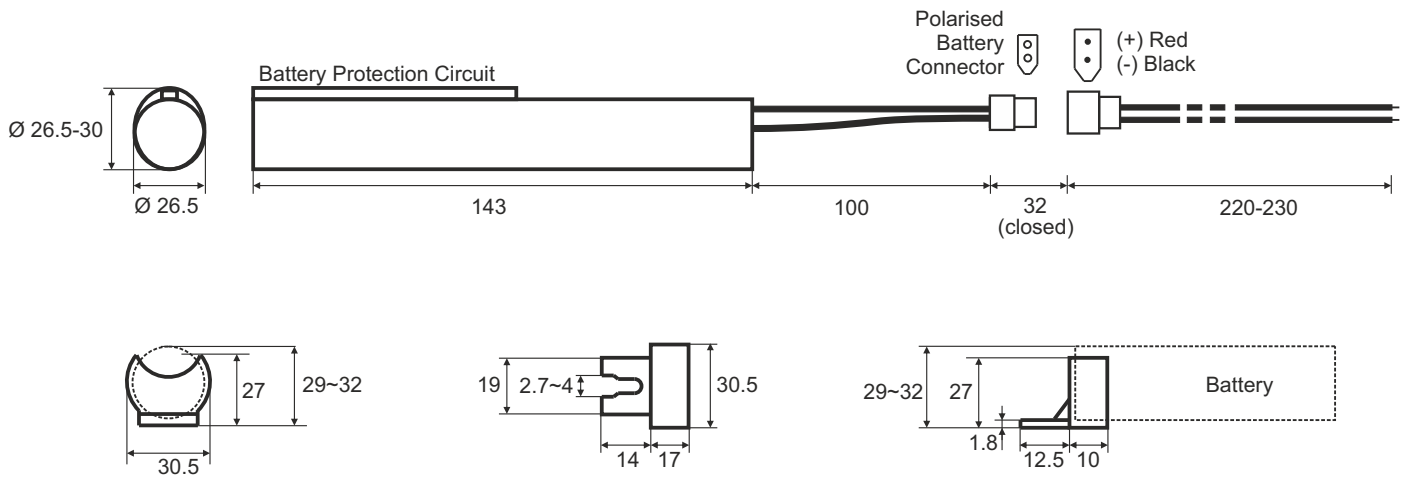

Battery Type : 6.4V-3.8Ah Li-FePO4



	LI-FEPO4 BATTERY MOUNTING PARTS	Designed	K.Bentlioglu	Date	13.01.2023	Scale	-
		Approved		Rev	R13012023	Page	1 / 1

BAT-HT32-1600LFL

3.2V-1.6Ah Li-FePO4 Battery Pack

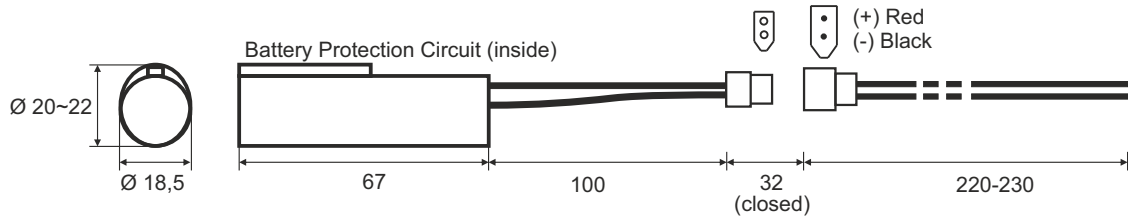

BAT-HT32-1600LFL-3P

3.2V-1.6Ah Li-FePO4 Battery Pack

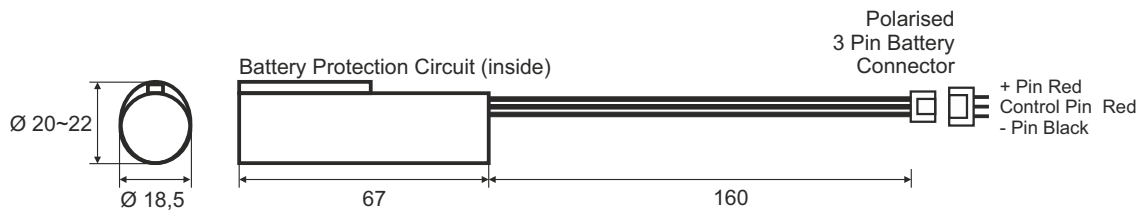

Battery Type : 3.6V - 1.7Ah Ni-Cd

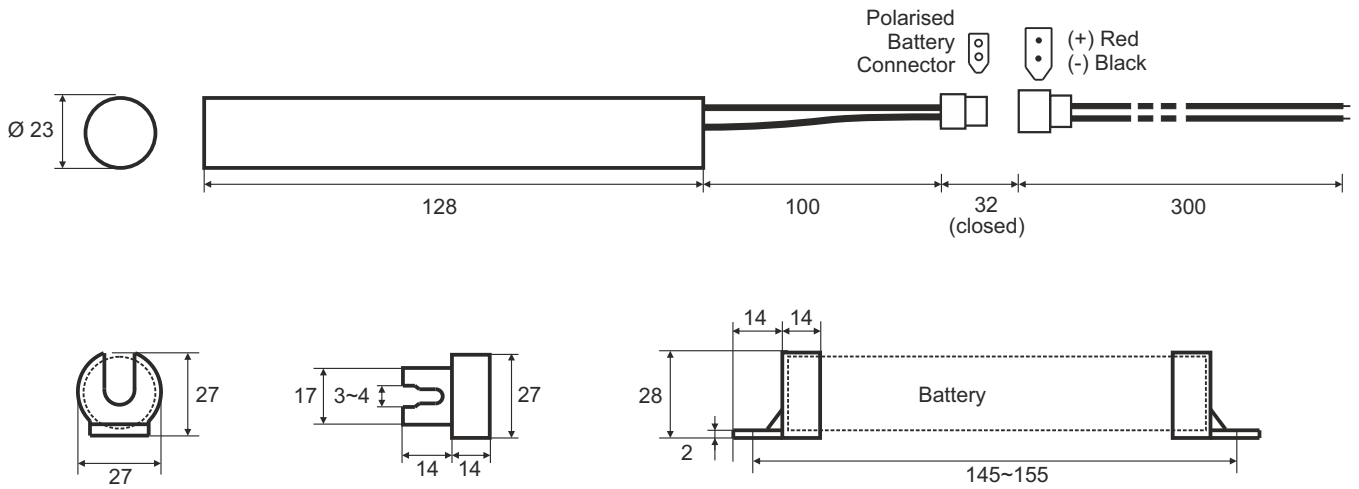

Battery Type : 3.6V - 4.5Ah Ni-Cd

